

# ERGOTIG 24W

CE EN60974-7



CODE	↔		↔	⚡
SY1410-00	4 m	12.5'	sintig	TSK 50-1/4G
SY1810-00	8 m	25'	sintig	
SZ1410-00	4 m	12.5'	sintig flex	
SZ1810-00	8 m	25'	sintig flex	

TECHNICAL DATA	
<b>ERGOTIG 24W</b>	
	0,45 kg      0.99 lb
<b>V PEAK</b>	113
	Argon
$\emptyset$	0,5 ÷ 2,4 mm      .020" ÷ 3/32"
<b>X 100%</b>	180A DC - 120A AC
	4 bar
	1.5 l/min

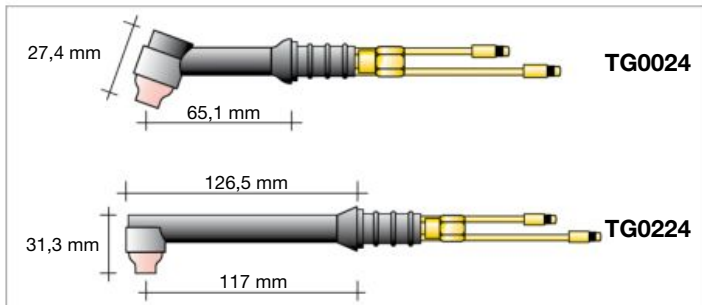

	CODE			
4	TQ0004		insulator	10
5	TG0024		tig 24W torch head - 65,1 mm	1
6	TG0224		tig 24W flex torch head - 117 mm	1
8	TT0181		kit Ergotig single	1
9	TT0182		kit Ergotig dual	1
10	BW0304		reduction	1
10	BW0311		cable joint	1
10	EA0329		screw	50
10	TP0090		Ergotig handle	1
11	TH0147		cable assembly - 4 m / 12.5'	1
11	TH0148		cable assembly - 8 m / 25'	1
12	TH0086		power cable - 4 m / 12.5'	1
12	TH0087		power cable - 8 m / 25'	1
15	CX0080		TSK 50 - quick plug	1



**WEAR PARTS NOT INCLUDED**

Starter kits page 360  
Wear parts page 364

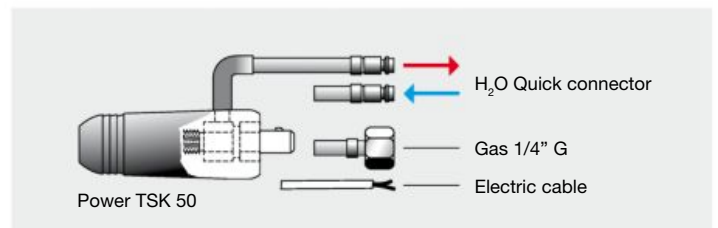

**SERIES 24 - 24W WEAR PARTS**



**1**



**2**







**3**







**4**

**STANDARD**

	CODE		Gr	Ø		↔	REF	
1	TC0021		.165	4 mm	5/32"	16 mm	53N23	10
1	TC0022		4	6,4 mm	1/4"	16,5 mm	53N24	10
1	TC0023		5	8 mm	5/16"	15,6 mm	53N25	10
1	TC0024		6	9,8 mm	3/8"	15,6 mm	53N27	10
1	TC0027		4	6,4 mm	1/4"	29 mm	53N28	10
1	TC0028		6	9,8 mm	3/8"	29 mm	53N26	10
2	TE0004-05			0,5 mm	.020"	12 mm	53N17	10
2	TE0004-10			1,0 mm	.040"	12 mm	53N18	10
2	TE0004-16			1,6 mm	1/16"	12 mm	53N19	10
2	TE0004-24			2,4 mm	3/32"	12 mm	24CB332	10
3	TD0004-10			1,0 mm	.040"	14 mm	53N16	10
3	TD0004-16			1,6 mm	1/16"	14 mm	53N14	10
3	TD0004-24			2,4 mm	3/32"	14 mm	24C332	10
4	TQ0004						53N22	10

**GAS LENS**

	CODE		Gr	Ø		↔	REF	
1	TC0041		4	6,4 mm	1/4"	25,5 mm	53N58	10
1	TC0042		5	8 mm	5/16"	25,5 mm	53N59	10
1	TC0043		6	9,8 mm	3/8"	25,5 mm	53N60	10
1	TC0044		7	11,2 mm	7/16"	25,5 mm	53N61	10
1	TC0045		8	12,7 mm	1/2"	25,5 mm	53N61S	10
2	TE0005-05			0,5 mm	.020"	22 mm	45V41	10
2	TE0005-10			1,0 mm	.040"	22 mm	45V42	10
2	TE0005-16			1,6 mm	1/16"	22 mm	45V43	10
2	TE0005-20	Cu + CuZn		2,0 mm	5/64"	22 mm		10
2	TE0005-24			2,4 mm	3/32"	22 mm	45V44	10
3	TD0005-05			0,5 mm	.020"	23 mm	53N62	10
3	TD0005-10			1,0 mm	.040"	23 mm	53N63	10
3	TD0005-16			1,6 mm	1/16"	23 mm	53N64	10
3	TD0005-24			2,4 mm	3/32"	23 mm	24GLC332	10
4	TQ0024						53N66	10